



Model P-600 SIC Analyzer

On-line Salt In Crude Analyzer for continuous measurement of the concentration of salt in crude oil

- ▶ Measurement range of 0-400 PTB (0-1000 mg/lit.)
- ▶ Rapid analysis cycle of 6 minutes or less
- ▶ Superior repeatability of 2% of scale
- ▶ Reliability better than 99% uptime
- ▶ Incorporated rinse/flush system
- ▶ Optional validation/grab sample system



The Model P-600 Salt In Crude Analyzer is the result of combining the latest, state-of-the-art technology with over 20 years of industry experience. The result is an unsurpassed, high-quality Salt In Crude measurement system that produces the process control signal required to perform in today's optimized and cost-driven petroleum market place.

Using a simply constructed, yet rugged, measurement chamber and sample delivery method, operational cost savings have been realized without complicating the analytical system. The P-600 demonstrates the optimization of the fluidics paths by employing components and materials that allow for a rapid measurement cycle without limiting accuracy, repeatability or reliability.

APPLICATION

In certain areas of the world, crude oils with high level of salts exist. This crude oil must still be transported and refined and the high levels of salt pose problems if left untreated. De-Salting technology is well established but to be utilized effectively the need for quick and accurate measurements of the level of salt concentration is necessary. The immediate response of an on-line analyzer allows the operator to use De-Salters as efficiently as possible.

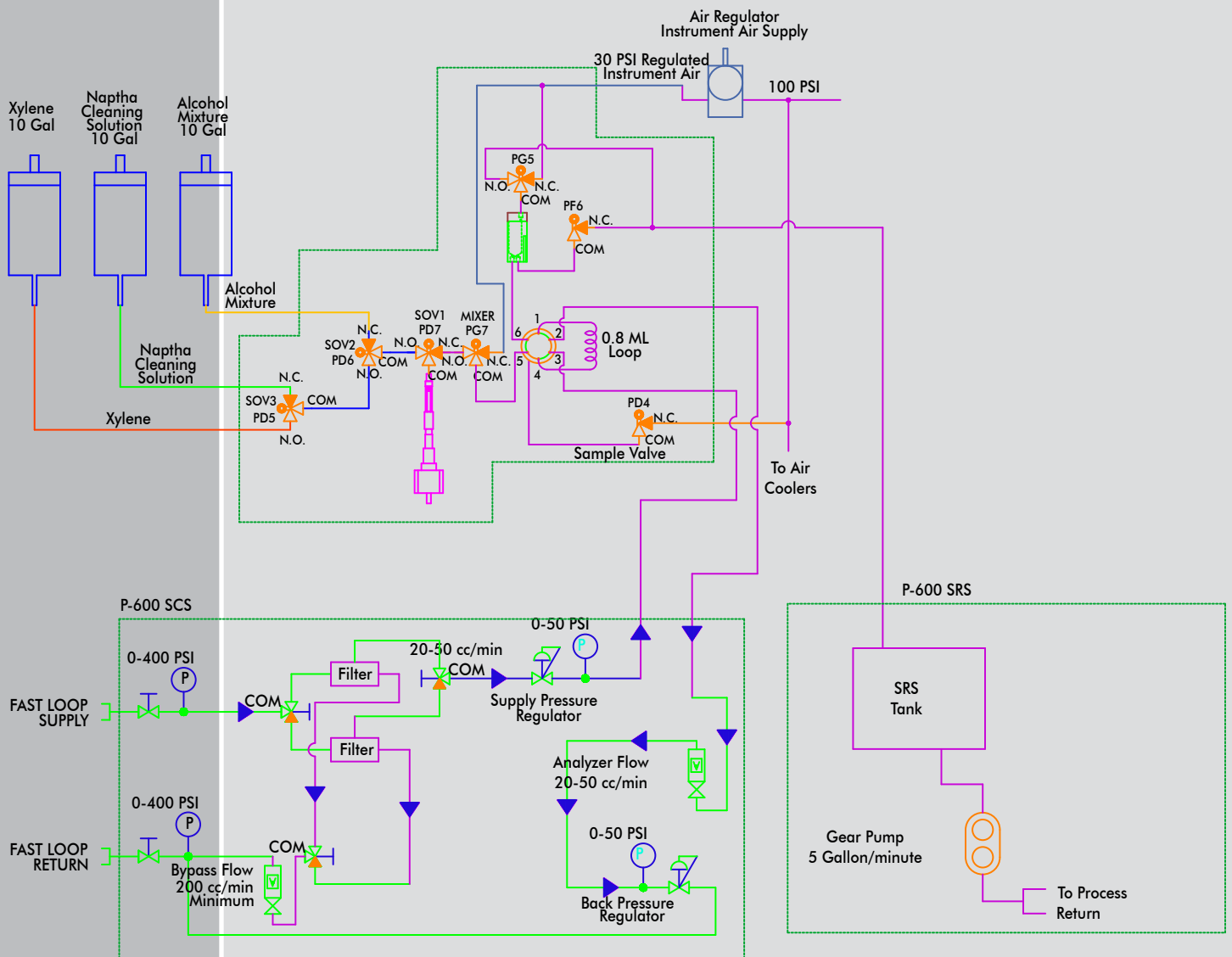

OPERATING PRINCIPLE

The P-600 Salt In Crude analyzer's measurement cycle is based on the ASTM Method D 3230. This is done by using a digitally controlled syringe sample handling system, micro-volume solenoid valves and a measurement chamber equipped with a high-resolution conductivity probe, stirrer and temperature control.

First, the sample chamber is emptied by opening the sample drain and the measurement chamber pressure valve. By utilizing the purge gas, any remaining fluid and vapors are removed. This is followed by a measurement chamber rinsing sequence, where the chamber and stirrer are rinsed and cleaned with Naptha at programmed times.

Second, the Crude sample loop solenoid is actuated, bringing a precisely measured amount of crude oil into the tubing path to the measurement cell. Then using the digitally controlled syringe, a precise volume of Xylene is drawn from a solvent chamber and it is then pushed through the crude sample loop into the measurement cell. Then a precise volume of Alcohol is drawn from a solvent chamber and it is then pushed through the crude sample loop into the measurement cell.

Prior to the measurement phase, the stirrer is activated and operated for the duration of the analysis cycle, in order to shorten the analysis time. The measurement chamber temperature is monitored and held at a programmed level (normally 45C to 50 C). The analysis is completed once the sample temperature equilibrium is reached and the conductivity signal has met its stabilization criteria.

Once stabilized the conductivity measurement is made, the Salt In Crude level is calculated and reported. Then the sample is flushed from the cell and a rinse cycle is initiated to keep the measurement cell clean. After the rinse cycle the next cycle can then be started immediately. A delayed mode of operation can also be used to save on the consumption of solvents.

By continuously tracking the conductivity and temperature signals during the analysis cycle, the diagnostic function checks the system for abnormal events. The VisioGraph advanced diagnostic routine not only provides end users with immediate knowledge of the condition of the analyzer, it also offers suggestions for troubleshooting.

To further enhance the precision and usefulness of the Model P-600 SIC Analyzer, an optional validation/grab sample system can be added. This allows the end user to either introduce a reference solution or an unknown sample for immediate analysis. This feature provides a simple system verification or a quick analysis of a non-automated sample stream.

DIMENSIONS inch (mm)

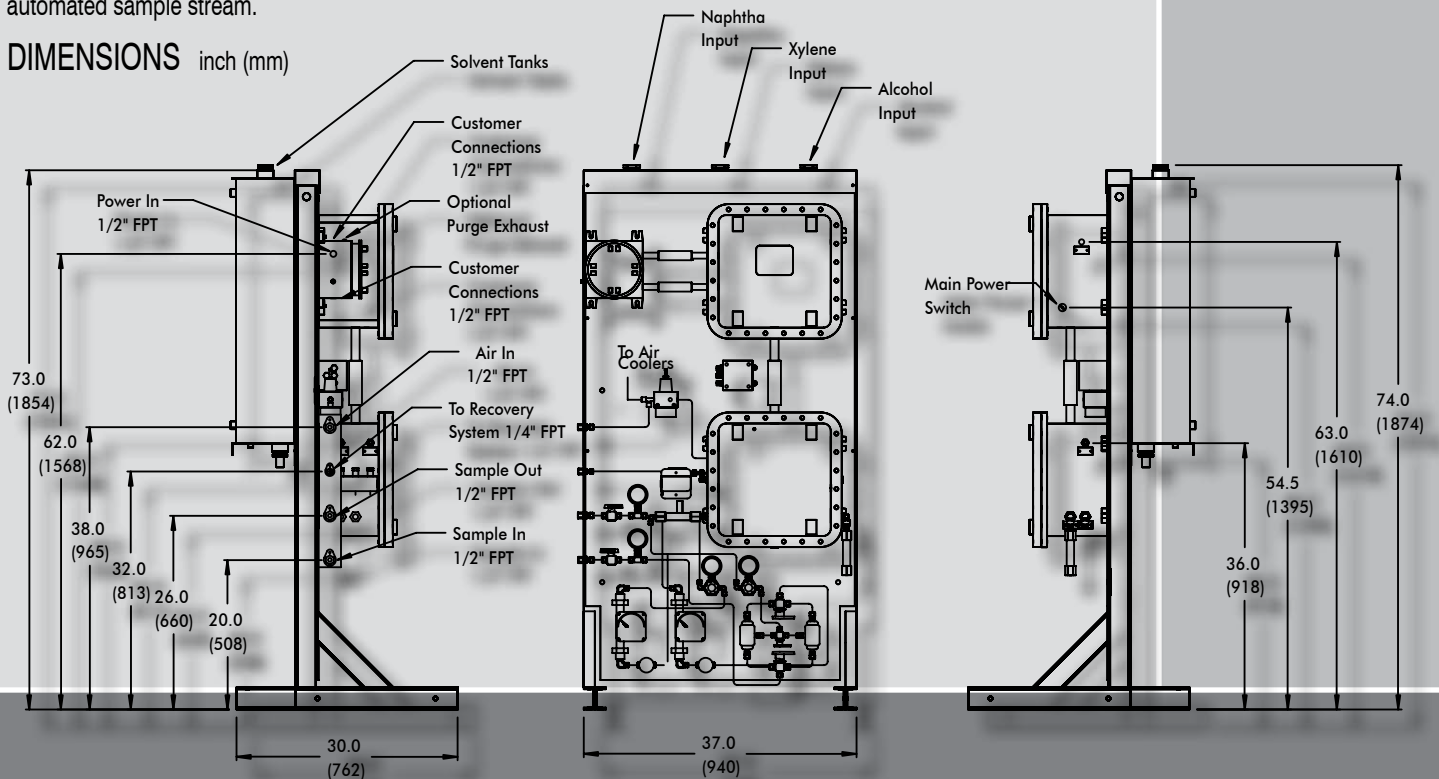



PRODUCT GUIDE

Petroleum Analyzers

- Flash Point
- Salt In Crude
- RVP
- RVP/VL20
- Freeze Point
- Cloud Point
- Pour Point
- Viscosity
- Viscosity Index

Water Analyzers

- UV-COD
- UV-Oil in Water

Other Products

- Environmental Cabinets
- Sample Conditioning Systems
- Sample Recovery Systems
- Spare Parts

Analyzer Services

- Field Service
- Start-Ups
- Training
- Technical Support



SPECIFICATIONS: MODEL P-600 SALT IN CRUDE ANALYZER

ANALYSIS PERFORMANCE	
Measurement Cycle Time	6 minutes or less
Measurement Range	0 to 400 PTB, 0 to 1000 mg/liter (selectable)
Repeatability	2 % of scale or better
Reproducibility	± 1 % of scale
Resolution	± 0.5 % of scale
Accuracy	+/- 5% of measurement, correlates to ASTM D 3230
Conductivity Accuracy	0.5 % of full scale
Temperature Accuracy	± 0.1°C (± 0.2°F) of full scale
SAMPLE REQUIREMENTS	
Sample Bypass Flow Rate	2.0 L/min
Sample Return Pressure	Atmospheric – Max. 35 psi (2.4 bar) - optional high pressure sample recovery system available (P/N 700172)
Sample Pressure	Min. 60 psi (4.0 bar) – Max. 210 psi (14.0 bar) - optional sample conditioning system heating option exists
Sample Temperature	Min. 50°F (10°C) – Max. 140°F (60°C)
Sample Conditions	homogenous, single-phase sample without water
ENCLOSURE/INSTALLATION REQUIREMENTS	
Dimensions	Width 38.0 in (954mm) – Height 73.0 in (1854mm) – Depth 30 in (762mm)
Weight	approximately 500 lbs (228 kg)
Operating Temperature	Min. 40°F (5°C) – Max. 105°F (40°C)
Enclosure Material/Rating	X-Proof housings
Area Classification	NEC Class 1 Div 1 Group B, C + D
Power	auto-selecting 100 to 120 VAC or 200 to 240 VAC (± 10%), 50/60 Hz, single phase, 5A
Optional Vortex Gas Supply	Clean, Dry Instrument air at Min. 80 psi (5.5 bar) – Max. 120 psi (8.2 bar)
Cell Purge Gas Supply	Clean, Dry Instrument air at Min. 20 psi (1.4 bar) – Max. 35 psi (2.4 bar) / approx. 20 ccm/min flow rate at 20% duty cycle
END USER CONNECTIONS	
Analog Output Signal	single isolated 4-20 mA output (optional second output available), selectable for sample SIC values, analyzer system/maintenance warning or analysis measurement indication
Relay Output Contact	three SPDT Relays with contacts rated at 3A resistive load at 250VAC, selectable for sample SIC value alarm, analyzer maintenance warning or analyzer fault alarm
Serial Input/Output Signal	single RS232 or RS485 bi-directional / optional ModBus output available
SOLVENT REQUIREMENTS	
Xylene	per ASTM D843
Alcohol Mixture	37/63 mix of Absolute Methanol and n-Butanol (reagent grade)

HOW TO ORDER

ANALYZER SYSTEMS	
Catalog Number P-600-1400	Orb Model P-600 RVP Analyzer, Ex Area ready for NEC Class 1 Div 1 Group C + D
ACCESSORIES	
Catalog Number 700228	High Pressure Sample Recovery System (for sample return pressures greater than 35 psi (2.4 bar) up to Max. 120 psi (8.3 bar))
Catalog Number 700641	1-Year Spare Parts Kit
Catalog Number 700642	2-Year Spare Parts Kit

Lit. No. P-600XP-EN-US / JAN10

ORB Instruments, Inc.
 4724 South Christiana
 Chicago, IL 60632 / USA
 Phone: + (1) 773 927-8600
 Fax: + (1) 773 927-8620
 Email: sales@orbinstruments.com
www.orbinstruments.com