



Model P-780 RVP/VL20 Analyzer

**On-line RVP or VL20 Analyzer
for the continuous measurement
of vapor pressure in petroleum
products.**

- ▶ Can be operated in RVP, VL20 or dual mode (alternating RVP & VL20)
- ▶ Operating range
RVP 0-35 psi
VL20 25°C to 65°C
- ▶ Rapid analysis cycle of 5 minutes or less
- ▶ Superior repeatability
RVP less than 0.05 psi
VL20 less than 1°F (0.5°C)
- ▶ Increased reliability with operating uptime greater than 99%



The Model P-780 RVP/VL20 Analyzer is the result of combining the latest, state-of-the-art technology with over 20 years of industry experience. The result is an unsurpassed, high-quality Vapor Pressure measurement system that produces the process control signal required to perform today's optimized and cost-efficient petroleum blending operation.

Using a simply constructed, yet rugged, measurement chamber and sample delivery method, operational cost savings have been realized without complicating the analytical system. The P-780 demonstrates the optimization of the fluidics paths by employing components and materials that allow for a rapid measurement cycle without limiting accuracy, repeatability or reliability.

APPLICATION

With the introduction of the Clean Air Act and its amendments in 1990 by the Environmental Protection Agency under Title II Emission Standards for Moving Sources, Part A - Motor Vehicle Emission and Fuel Standards, Section 211 Regulation of Fuels - (h) Reid Vapor Pressure Requirements, it has become unlawful to sell, offer for sale, dispense, supply, offer for supply, transport, or introduce into commerce gasoline with a Reid Vapor Pressure in excess of 9.0 pounds per square inch (psi) during the high ozone season (as defined by the Administrator). With the introduction of Reformulated Gas the VL20 regulations have also become a controlling parameter especially during the summer months.

Therefore, refineries, pipeline terminals and blending stations require a reliable and accurate analysis system of the RVP/VL20 to comply with these regulations. In addition, the very same analysis system will allow the operator to run the blending process in an optimized range, lowering production cost and improving product quality.

OPERATING PRINCIPLE

The P-780's RVP measurement cycle is based on the ASTM Methods D-323, D-4953 and D-5482 by using a digitally controlled syringe sample handling system, micro-volume solenoid valves and an angled measurement chamber equipped with a high-resolution pressure sensor and magnetic stirrer.

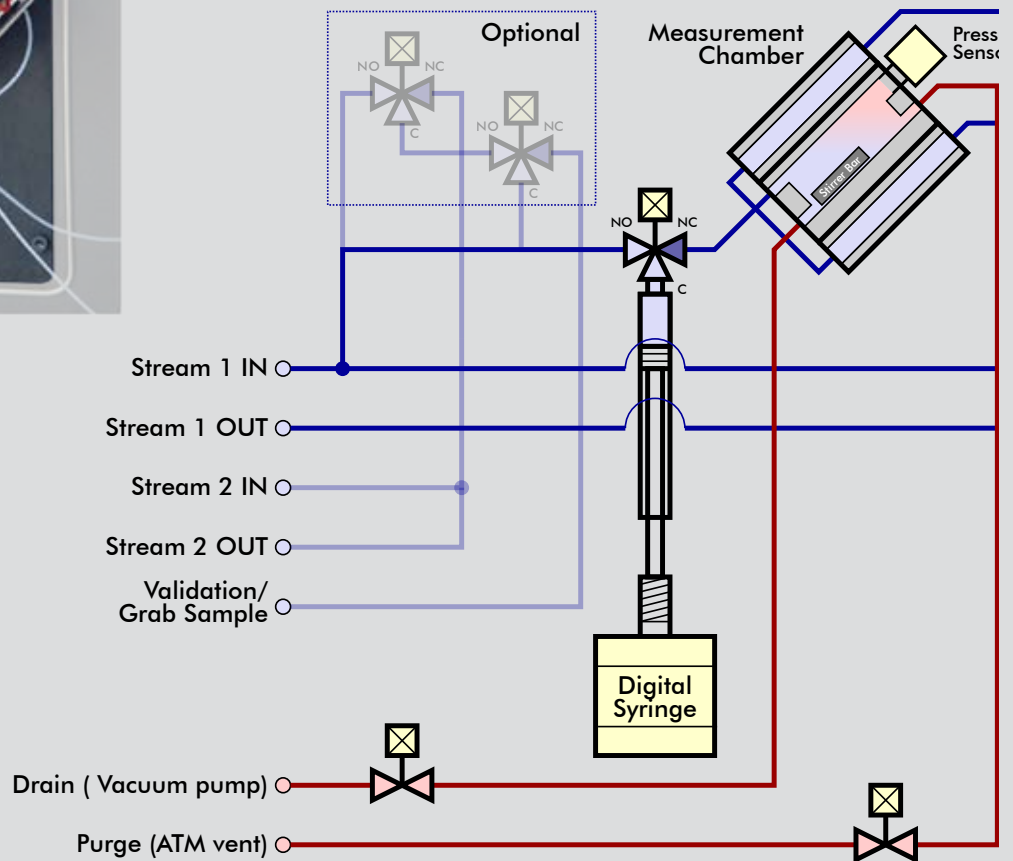

First, the sample chamber is emptied by opening the sample drain and the measurement chamber vent valve. By utilizing the vacuum source, any remaining fluid and vapors are removed. This is followed by a measurement chamber zeroing sequence, where the chamber and pressure sensor are normalized and the measurement baseline is established.

Second, with the digitally controlled syringe, a known gas volume is precisely drawn from the measurement chamber to be subsequently replaced by a known fluid sample volume drawn from the sample stream. This establishes the required 4:1 ratio of gas to fluid. Closing the measurement chamber sample valve starts the analysis cycle.

Prior to the measurement phase, the magnetic stirrer is activated and operated for the duration of the analysis cycle, in order to shorten the analysis time. The measurement chamber temperature is monitored and held at 100°F (37.8°C). The analysis is completed once the measurement equilibrium is reached and the signal has met its stabilization criteria.

The P-780's VL20 measurement cycle is based on the ASTM Method D-5188.

First, the sample chamber is emptied by opening the sample drain and the measurement chamber vent valve. By utilizing the vacuum source, any remaining fluid and vapors are removed. This is followed by a measurement chamber zeroing sequence, where the chamber and pressure sensor are normalized and the measurement baseline is established.

Second, the chamber is fully evacuated by leaving only the sample drain valve open to the chamber. This establishes a completely evacuated chamber per test method. Then using the digitally controlled syringe, sample (1/20 the chamber volume) is injected into the evacuated chamber. Closing the measurement chamber sample valve starts the analysis cycle, where the sample is agitated and the chamber temperature is raised or lowered to equalize to atmospheric zero pressure. This temperature is reported as the VL20 results and cycle is repeated.

By continuously tracking the pressure signal during the RVP/VL20 analysis cycles, the diagnostic function checks the fluidics system for leaks, drifts and other abnormal events. The VisioGraph advanced diagnostic routine not only provides end users with immediate knowledge of the condition of the analyzer, it also offers suggestions for troubleshooting.

To further enhance the precision and usefulness of the Model P-780 RVP/VL20 Analyzer, an optional validation/grab sample system can be added. This will allow the end user to either introduce a reference solution or an unknown sample for immediate analysis. This feature provides a simple system verification or a quick analysis of a non-automated sample stream. The optional dual-stream sampling system offers an economic way of automatically monitoring two sample streams with a minimal loss of measurement response time.

DIMENSIONS inch (mm)

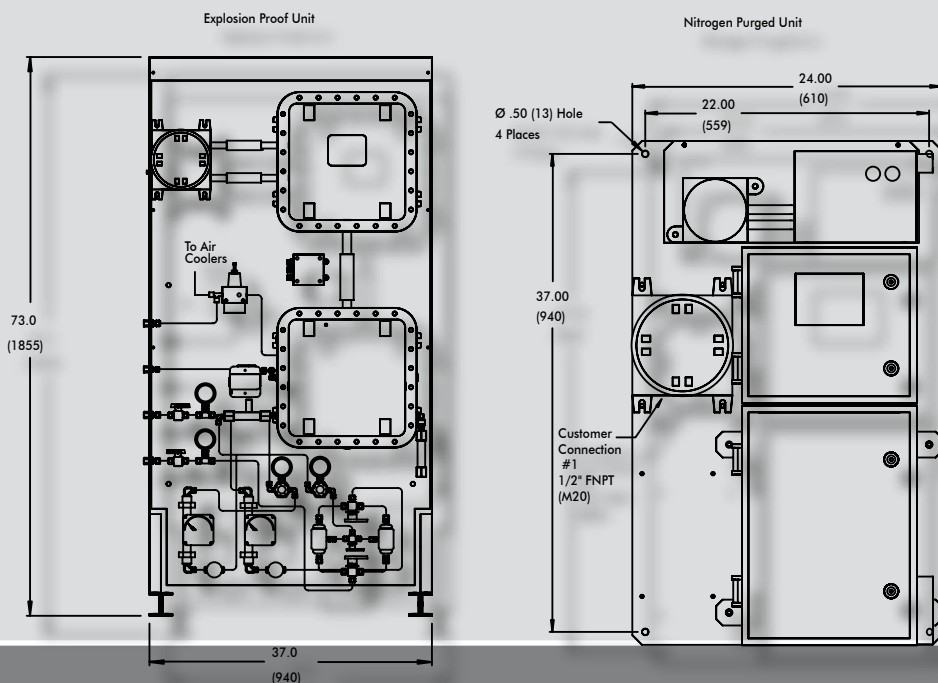

PRODUCT GUIDE

Petroleum Analyzers

- Flash Point
- Salt In Crude
- RVP
- RVP/VL20
- Freeze Point
- Cloud Point
- Pour Point
- Viscosity

Water Analyzers

- UV-COD
- UV-Oil in Water

Other Products

- Environmental Cabinets
- Sample Conditioning Systems
- Sample Recovery Systems
- Spare Parts

Analyzer Services

- Field Service
- Start-Ups
- Training
- Technical Support



SPECIFICATIONS: P-780 RVP/VL20 ANALYZER

ANALYSIS PERFORMANCE	
Measurement Cycle Time	5 minutes or less, dual mode 15 minutes or less
Measurement Range (RVP)	0 – 35 psi / 0 – 2.4 bar / 0 – 2400 mbar / 0 – 240 kPa / 0 – 2400 hPa (selectable)
Measurement Range (VL20)	25°C to 65°C (80°F to 150°F) (selectable)
Repeatability	± 0.05 psi (± 0.0035 bar), ± 1.0°F
Reproducibility	± 0.1 psi (± 0.007 bar), ± 2.0°F
Resolution	± 0.01 psi (± 0.0007 bar)
Accuracy	Meets or exceeds ASTM Methods D-323, D-4953, D-5482, D-5181 & D-5188
Pressure Accuracy	± 0.01% of full scale
Temperature Accuracy	± 0.1°C (± 0.2°F) of full scale
SAMPLE REQUIREMENTS	
Sample Bypass Flow Rate	Min. 0.04 L/min – Max. 0.1 L/min
Sample Return Pressure	Atmospheric – Max. 35 psi (2.4 bar) - optional high pressure sample recovery system available (P/N 700172)
Sample Pressure	Min. 20 psi (1.4 bar) – Max. 35 psi (2.4 bar) - optional sample conditioning system available (P/N 700173)
Sample Temperature	Min. 35°F (2°C) – Max. 120°F (50°C)
Sample Particulates	less than 10 µm - optional sample conditioning system available (P/N 700173)
Sample Conditions	homogenous, single-phase sample without water or water moisture
ENCLOSURE/INSTALLATION REQUIREMENTS	
Dimensions (Purged)	Width 24.0 in (610mm) – Height 39.0 in (991mm) – Depth 9.51 in (242mm)
Dimensions (Exd)	Width 37.0 in (940mm) – Height 73.7 in (1874mm) – Depth 30.0 in (762mm)
Weight	Purged Unit 150 lbs (68 kg) / Exd Unit 500 lbs (228 kg)
Operating Temperature	Min. 40°F (5°C) – Max. 105°F (40°C)
Enclosure Material/Rating	stainless steel - NEMA 4X / IP65
Area Classification	NEC Class 1 Div 1 Group B, C + D or ATEX Zone1 II B + H2 T4
Power	self-selecting 100 to 125 VAC or 200 to 240 VAC, 50/60 Hz, single phase, 2A
Cabinet Purge Gas Supply	Clean, dry Nitrogen or other inert gas (better than 98% pure) at Min. 40 psi (2.7 bar) – Max. 100 psi (6.8 bar) expected leakage compensation 1 l/min
Purge System Air Logic Supply	Instrument grade air at Min. 40 psi (2.7 bar) – Max. 100 psi (6.8 bar)
END USER CONNECTIONS	
Analog Output Signal	single isolated 4-20 mA output (optional second output available), selectable for sample RVP/VL20 values, analyzer system/maintenance warning or analysis measurement indication
Relay Output Contact	three SPDT Relays with contacts rated at 3A resistive load at 250VAC, selectable for sample RVP value alarm, analyzer maintenance warning or analyzer fault alarm
Serial Input/Output Signal	single RS232 or RS485 bi-directional / optional ModBus output available

HOW TO ORDER

ANALYZER SYSTEMS	
Catalog Number P-780-1100	ORB Model P-780 RVP Analyzer, Ex Area ready for NEC Class 1 Div 1 Group C + D
Catalog Number P-780-1200	ORB Model P-780 RVP Analyzer, Ex Area ready for ATEX Zone1 II B + H2 T4
Catalog Number P-780-1400	ORB Model P-780 RVP Analyzer, NEC Class 1 Div 1 Group B, C + D
OPTIONS	
Catalog Number 700170	Validation/Grab Sample System, Micro Flow
Catalog Number 700171	Dual-Stream Sampling System, Micro Flow
ACCESSORIES	
Catalog Number 700174-P780	Free-standing Mounting Rack
Catalog Number 700175	1-Year Spare Parts Kit
Catalog Number 700176	2-Year Spare Parts Kit

ORB Instruments, Inc.
 4724 South Christiana
 Chicago, IL 60632 / USA
 Phone: + (1) 773 927-8600
 Fax: + (1) 773 927-8620
 Email: sales@orbinstruments.com
www.orbinstruments.com